

CHEMICAL ENGINEERING

Chemical Technology



Comprehensive Theory
with Solved Examples and Practice Questions





MADE EASY Publications Pvt. Ltd.

Corporate Office: 44-A/4, Kalu Sarai (Near Hauz Khas Metro Station), New Delhi-110016 | **Ph. :** 9021300500

Email : infomep@madeeasy.in | **Web :** www.madeeasypublications.org

Chemical Technology

© Copyright by MADE EASY Publications Pvt. Ltd.

All rights are reserved. No part of this publication may be reproduced, stored in or introduced into a retrieval system, or transmitted in any form or by any means (electronic, mechanical, photo-copying, recording or otherwise), without the prior written permission of the above mentioned publisher of this book.



MADE EASY Publications Pvt. Ltd. has taken due care in collecting the data and providing the solutions, before publishing this book. In spite of this, if any inaccuracy or printing error occurs then **MADE EASY Publications Pvt. Ltd.** owes no responsibility. We will be grateful if you could point out any such error. Your suggestions will be appreciated.

EDITIONS

First Edition : 2021
Second Edition : 2022
Third Edition : 2023
Fourth Edition : 2024
Fifth Edition : 2025
Sixth Edition : 2026

CONTENTS

Chemical Technology

CHAPTER 1

Inorganic Chemical Industries 1-18

- 1.1 Sulphur and Sulphuric Acid Industry 1
- 1.2 Sulphuric Acid 4
- 1.3 Comparison of Vanadium and Platinum Catalyst 7
- 1.4 Chlor-Alkali Industry 7
- 1.5 Dual Process [Modified Solvay Process] 10
- 1.6 Sodium Hydroxide (NaOH) and Chlorine (Cl₂) 11
- Student Assignments* 14

CHAPTER 2

Fertilizer Industry 19-30

- 2.1 Introduction 19
- 2.2 Primary Nutrients and Their Functions 19
- 2.3 Ammonia 20
- 2.4 Nitric Acid (HNO₃) 21
- 2.5 Urea 23
- 2.6 Phosphorous 25
- 2.7 Phosphoric Acid (H₃PO₄) 26
- 2.8 Calcium Phosphates 26
- Student Assignments* 29

CHAPTER 3

Organic Industries 31-52

- 3.1 Introduction 31
- 3.2 Chemical Structure 32
- 3.3 Methods of Extracting of Oils and Fats 32
- 3.4 Extraction of Vegetable Oils 33
- 3.5 Hydrogenation of Oil 33
- 3.6 Reactions 35
- 3.7 Important Characteristics of Oils and Fats 35
- 3.8 Soaps and Detergents: Glycerin 35

- 3.9 Function of Soaps and Detergents 36
- 3.10 Carbohydrates and Fermentation Industries 38
- 3.11 Pulp and Paper Industry 45
- Student Assignments* 50

CHAPTER 4

Polymer Industries 53-77

- 4.1 Introduction 53
- 4.2 Polymers 53
- 4.3 Monomers 53
- 4.4 Classification Based on Physical and Chemical Structure 53
- 4.5 Classification based on Preparation Methods 58
- 4.6 Classification of Polymers Based on Their Applications 60
- 4.7 Polymer Manufacturing Processes 61
- 4.8 Elastomers (Rubbers) 67
- 4.9 Fibers 70
- Student Assignments* 75

CHAPTER 5

Petroleum Industries 78-106

- 5.1 Crude Oil 78
- 5.2 Refining Process 78
- 5.3 Crude Distillation Unit (CDU) 83
- 5.4 Cracking 86
- 5.5 Reforming 90
- 5.6 Isomerisation 91
- 5.7 Hydroprocessing 92
- 5.8 Alkylation 96
- 5.9 Visbreaking and Coking 99
- 5.10 Gas Processing 102
- 5.11 Olefin Polymerization 103
- Student Assignments* 104

CHAPTER 6**Petrochemical Industries..... 107-140**

6.1	Production of Methanol from Synthesis Gas.....	108
6.2	Manufacture of Formaldehyde from Methanol.....	109
6.3	Production of Chloromethanes.....	110
6.4	Steam Cracking for Petrochemicals.....	111
6.5	Vinyl Chloride from Ethylene.....	113
6.6	Production of Ethylene Oxide and Ethanolamines.....	115
6.7	Production of Isopropanol and Acetone.....	117
6.8	Production of Cumene.....	120

6.9	Production of Acrylonitrile.....	121
6.10	Production of Butadiene.....	122
6.11	Production of Benzene by Hydrodealkylation Route.....	123
6.12	Production of Isoprene.....	124
6.13	Oxoprocessing of Olefins.....	126
6.14	Production of Phenol.....	128
6.15	Production of Styrene.....	133
6.16	Production of Pthalic Anhydride.....	135
6.17	Production of Maleic Anhydride.....	136
	<i>Student Assignments</i>	139

Process description:

- Treated water is sent to domes at 160 - 180° and 25 atm.
- Molten sulphur sinks to the bottom of casing.
- Sump-separation units are used.
- Filtration is sometimes used to remove contaminants.
- Treated water is used to avoid scaling and corrosion.

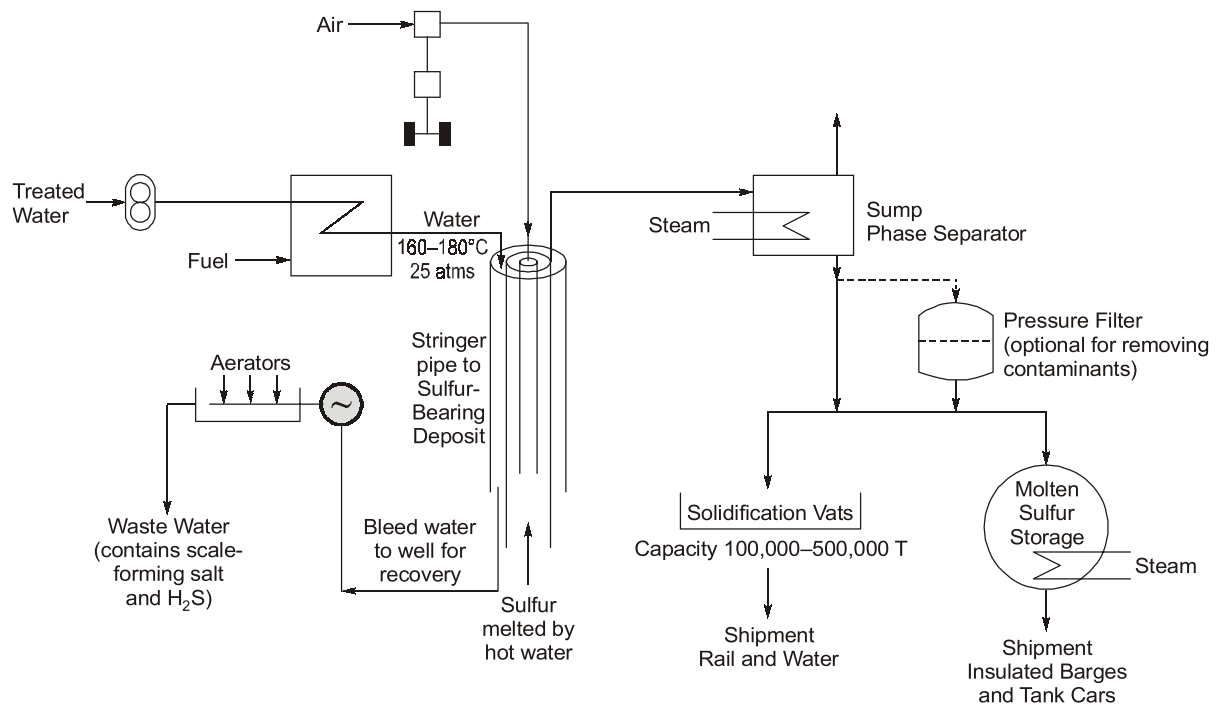

Fig. : Elemental sulfur mining by Frasch process

2. Oxidation and Reduction of H_2S :

Raw materials:

- H_2S from natural gas and petroleum refinery.

Reactions:

- $2H_2S + 3O_2 \rightleftharpoons 2SO_2 + 2H_2O$ (Exothermic)
- $4H_2S + 2SO_2 \rightarrow S_6(g) + 4H_2O$ (Exothermic)

Process:

It consists of two-stage catalytic converter with interstage cooling.

First stage:

- Catalyst: Bauxite
- Operated at 300° - 400° C
- 70 - 80% conversion achieved
- Exothermic SO_2 oxidation of H_2S

Second stage:

- Operated at 250 - 300° C

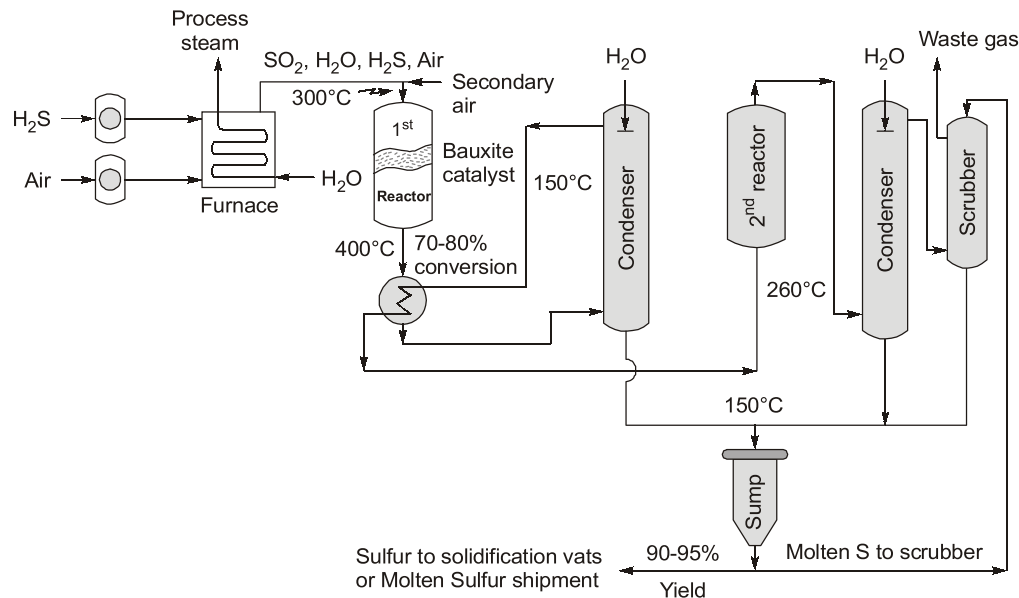

Fig. : Sulfur production by oxidation-reduction of H_2S

3. Elemental Sulphur from Pyrites (Finnish Process):

Raw materials:

- Pyrites ore [200 mesh]
- Limestone [To remove Silica]
- Water

Chemical reactions:

Thermal dissociation:

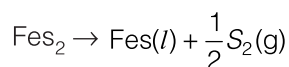

- General combustion reaction :**

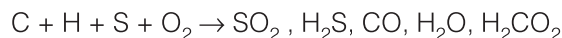

- Hot stage (sulphur recovery)**

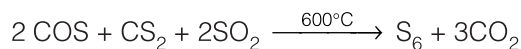

- Cold stage (sulphur recovery):**

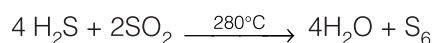

- Roasting of FeS

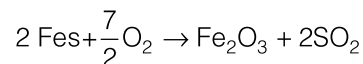

Co-products:

- SO_2 [From Fes roasting]
- Fe_2O_3 [From Fes rotating]

1.2 SULPHURIC ACID

Sulphuric acid is a highly corrosive strong dibasic mineral acid with the molecular formula (H_2SO_4). It is a pungent, colorless to slightly yellow viscous liquid which is soluble in water at all concentrations.

Physical Properties:

- Molecular formula : H_2SO_4
- Molecular Weight : 98.08 gram/mole
- Melting point : 10°C
- Boiling point : 290°
- Density : 1840 kg/m^3
- Solubility : Miscible with water in all proportions

1.2.1 Chemical Properties

- **Dehydrating agent:**
 - It is hygroscopic, readily absorbing water vapour from air.
 - Has great affinity for water and the reaction is extremely exothermic.
 - It forms mono and dihydrate with water, $\text{H}_2\text{SO}_4 \cdot \text{H}_2\text{O}$, $\text{H}_2\text{SO}_4 \cdot 2 \text{H}_2\text{O}$.
- **Oxidising agent:**
 - Gives O_2 on strong heating.
 - Hot con H_2SO_4 also acts as an oxidising agent.
- **Acidic nature:**
 - Strong basic acid
 - Forms two types of salts with alkalis
Bisulphates [HSO_4^-] ... NaHSO_4
Sulphates [SO_4^{2-}] ... Na_2SO_4
- **Manufacturing process:**
The industrial manufacture of sulphuric acid is done mainly by two processes.
 - The lead chamber process
 - The contact process

1.2.2 The Lead Chamber Process

1. This is an old process and uses Nitrogen oxides as oxygen carrying catalysts for the conversion of sulphur dioxide (SO_2) to sulphur trioxide (SO_3).
2. The production of sulphur trioxide and sulphuric acid takes place in the huge lead chambers and that's why the name lead chamber process.
3. Produces acid of concentration less than 80%.
4. All new plants use contact process, although.
5. Gives an yield of 98%.

Disadvantages:

1. Produces acid of low quality and concentration.
2. Limitations in throughput.

1.2.3 The Contact Process

In the contact process, sulphur dioxide is converted to sulphur trioxide using V_2O_5 catalyst. Platinum was initially used, but now replaced by V_2O_5 catalyst because of platinum's susceptibility to poisoning.

Catalyst:

6.2 - 6.5% V_2O_5 supported on silica and 1% potassium sulphate.

The V_2O_5 is dispersed on a porous carrier in a pellet form.

Raw materials:

- Sulphur dioxide or pyrites (FeS_2)
- Air

Chemical reactions:

Oxidation: $S + O_2 \rightarrow SO_2$ (Exothermic)

$2SO_2 + O_2 \rightleftharpoons 2SO_3$ (Exothermic)

Hydration: $SO_3 + H_2O \rightarrow H_2SO_4$

Process Description:

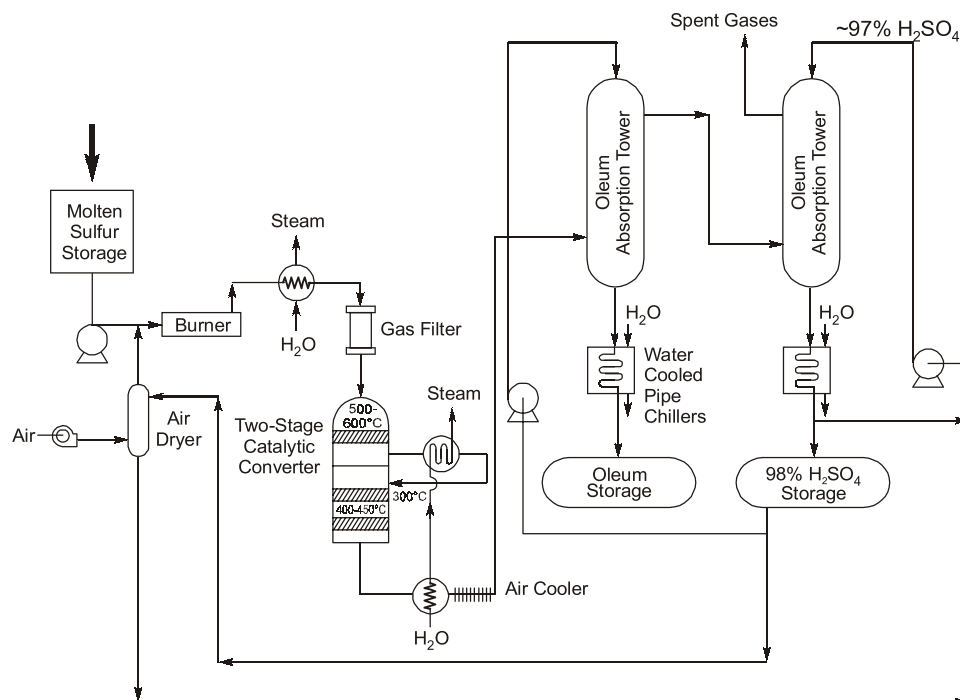

The steps in the process are as follows:

1. Burning of sulphur
2. Catalytic oxidation of SO_2 to SO_3
3. Hydration of SO_3 (oleum absorption)
4. Scrubbing with 97% H_2SO_4 .

1. Burning of sulphur:

- Burning of sulphur in presence of dry air is carried out in sulphur pyrite burner.
- Dry air is used to prevent corrosion.

2. Catalytic oxidation of SO₂ to SO₃:

This takes place in two stages:

Stage-1: High temperature (500 - 600°C)

Stage-2: Low temperature (400 - 450°C)

- Air - SO₂ mixture from burner containing 7 - 10% SO₂ and 11 - 14% O₂ is preheated if necessary.
- This mixture is sent into the high temperature stage which contains 30% of the catalyst and conversion about 80% of SO₂ is achieved.
- The converter product is cooled to 300°C and fed to second stage.
- In second stage, the yield increases to 97%.

3. Hydration of SO₃ [oleum absorption]:

- Sulphur trioxide hydration is done by absorption of SO₃ in 98 - 99% sulphuric acid in the oleum absorption tower.
- Oleum concentration upto 40% are achieved.

4. Scrubbing with 97% H₂SO₄:

- The oleum from the oleum absorption tower is scrubbed with 97% H₂SO₄ and the sulphuric acid of 98% concentration is achieved.

NOTE: Concentration of oleum is expressed in terms of sulphur trioxide and sulphuric acid.

Ex. 40% oleum means 40 kg to SO₃ in 60 kg to H₂SO₄.

1.2.4 Kinetics and Thermodynamics

The most important step that decides the yield of SO₃ in turn H₂SO₄ is the catalytic conversion of SO₂ to SO₃.

**Effect of temperature:**

- Being an exothermic reaction, this reaction can't be conducted at a higher temperature, because that decreases the formation of SO₃.
- At low temperature, the rate of combustion of SO₂ is very low.
- Hence, an optimum temperature of 450°C is selected as the operating temperature.

Effect of pressure:

- Formation of SO₃ is associated with decrease in volume, so increase in pressure is expected to increase the rate of formation of SO₃.
- But no significant increase in yield is observed at high pressures.
- Hence a pressure of 1.5 - 1.7 atms is selected.



Student's Assignments

- Q.1** Which of the following catalysts is employed for converting SO_2 to SO_3 in the contact process for sulphuric acid manufacture?
- (a) P_2O_5 (b) V_2O_5
(c) N_2O_5 (d) PCl_5
- Q.2** In the contact process for sulphuric acid manufacture, the feed gas entering the converter (where SO_2 is oxidized to SO_3) contains:
- (a) 0.1 – 1% SO_2 (b) 7–10% SO_2
(c) 20–30% SO_2 (d) 60–70% SO_2
- Q.3** There are two industrial processes for sulphuric acid manufacture (contact process and lead chamber process). The produced acid of lead chamber process is of concentration :
- (a) Less than 10%
(b) Less than 30%
(c) Less than 60%
(d) Less than 80%
- Q.4** In the normal contact process of sulphuric acid manufacture, sulphur dioxide to sulphur trioxide conversion efficiency is around
- (a) 20% (b) 50%
(c) 90% (d) 98%
- Q.5** In the double contact double absorption process for sulphuric acid manufacture, sulphur dioxide to sulphur trioxide conversion is more than that in normal contact process and is equal to
- (a) 98.2% (b) 98.5%
(c) 99.5% (d) 100%
- Q.6** In contact process, sulphur dioxide required can be produced either by burning elemental sulphur or by roasting iron, copper or zinc pyrites. In India majority of sulphuric acid plants still use
- (a) Elemental Sulphur
(b) Iron Pyrites
(c) Zinc Pyrites
(d) Copper Pyrites
- Q.7** Commercial catalyst used for sulphuric acid manufacture contains:
- (a) 6.2–6.5% vanadium pentoxide supported on silica and 1% potassium sulphate.
(b) 25% vanadium pentoxide supported on silica and 1% potassium sulphate.
(c) 50% vanadium pentoxide and 50% potassium sulphate mixture.
(d) 100% pure vanadium pentoxide.
- Q.8** 20% oleum is
- (a) 20% SO_3 in 80% H_2SO_4
(b) 20% SO_3 in 100% H_2SO_4
(c) 80% SO_3 in 100% H_2SO_4
(d) None of those
- Q.9** In the manufacture of sulphuric acid, the absorption of sulphur trioxide is done in
- (a) concentrated sulphuric acid
(b) water
(c) Both (a) and (b)
(d) Oleum
- Q.10** Advantages of V_2O_5 catalyst are :
- (a) Relatively immune to poisons
(b) Low initial investment
(c) Both (a) and (b)
(d) Catalyst is less active
- Q.11** Sulphur dioxide is dried by passing it through concentrated sulphuric acid. It is because concentrated sulphuric acid has a very strong affinity for water and reacts with it to form
- (a) $\text{H}_2\text{SO}_4 \cdot \text{H}_2\text{O}$ (b) $\text{H}_2\text{SO}_4 \cdot 2\text{H}_2\text{O}$
(c) $\text{H}_2\text{S}_2\text{O}_7$ (d) $\text{H}_2\text{SO}_4 \cdot \frac{1}{2}\text{H}_2\text{O}$
- Q.12** Sulphur dioxide is one of the starting compounds of sulphuric acid industry. It can be obtained by
- (a) Burning sulphur in air or oxygen
(b) By roasting zinc sulphide in air
(c) By roasting iron pyrites in air
(d) All of the above

- Q.13** Which one of the following compounds is called anhydride of sulphuric acid
(a) SO_3 (Sulphur trioxide)
(b) SO_2 (Sulphur dioxide)
(c) $\text{H}_2\text{S}_2\text{O}_7$ (Oleum)
(d) H_2SO_3 (Sulphurous acid)
- Q.14** Which one of the following compounds is used as bleaching agent
(a) SO_2 (Sulphur Dioxide)
(b) SO_3 (Sulphur Trioxide)
(c) N_2O (Nitrous Oxide)
(d) CO_2 (Carbon Dioxide)
- Q.15** Sulphuric acid is mainly used in
(a) Fertilizer Industry
(b) Polymer Industry
(c) Petroleum Industry
(d) Automobile Industry
- Q.16** In the contact process of sulphuric acid manufacture, 98% sulphuric acid is stored in
(a) Hastelloy steel
(b) Stainless steel
(c) Cast iron
(d) Durmet-20
- Q.17** Vanadium pentoxide is used as catalyst in sulphuric acid industry for conversion of SO_2 to SO_3 , what are the disadvantages of vanadium pentoxide catalyst
(a) Sulphur dioxide content in incoming air mixture should be limited to 7–10%.
(b) Require high $\text{O}_2 : \text{SO}_2$ ratio to give economic conversion.
(c) Catalyst is less active initially.
(d) Catalyst is easily poisoned by arsenic.
- Q.18** The conversion of Sulphur dioxide (SO_2) to Sulphur trioxide (SO_3) is favoured by : (strictly according to thermodynamics)
(a) Increase in temperature above 500°C
(b) Increase in pressure
(c) Decrease in temperature
(d) Decrease in pressure
- Q.19** Which one of the following catalysts is used in conversion of sulphur dioxide to sulphur trioxide in the manufacture of sulphuric acid before vanadium pentoxide
(a) Platinum (Pt)
(b) Nitrogen oxides
(c) Chromium oxide
(d) Nickel
- Q.20** Sulphur dioxide is produced by oxidation of Hydrogen sulphide (H_2S). Which one of the following catalysts is used during this process?
(a) Platinum (Pt)
(b) Vanadium Pentoxide (V_2O_5)
(c) Bauxite (Al_2O_3)
(d) Iron Oxide
- Q.21** Which of the following methods is correct for diluting sulphuric acid?
(a) Slowly mixing and adding water in sulphuric acid.
(b) Slowly mixing and adding sulphuric acid in water.
(c) Rigorous addition of water and sulphuric acid.
(d) All of the above
- Q.22** Sulphur is the primary raw material for the manufacture of sulphuric acid. Which of the following processes is used for the production of sulphur.
(a) Frasch process
(b) Claus process
(c) Finnish process
(d) Oxidation, reduction of H_2S
- Q.23** The reason why treated water is used in frasch process (elemental sulphur mining from salt domes using treated water)
(a) To avoid scaling of the equipment
(b) Treated water is lighter than untreated water
(c) Solubility of sulphur is more in treated water
(d) All of the above
- Q.24** Finnish process is used for the manufacture of sulphur, which is the raw material of sulphuric acid industry. What are the co-products of this process?

- (a) Sodium Carbonate (Na_2CO_3)
 (b) Sodium Bicarbonate (NaHCO_3)
 (c) Ammonium Chloride (NH_4Cl)
 (d) Calcium Chloride (CaCl_2)

Q.44 Which of the following processes for producing Sodium Hydroxide (NaOH) has denuding as an intermediate step?

- (a) Diaphragm Cell (b) Mercury Cell
 (c) Membrane Cell (d) All of the above

Q.45 Diaphragm cell, Mercury cell and Membrane cell processes produce Sodium Hydroxide, but the product slurry has some NaCl . Which one of the following sequence is correct for the content of NaCl present in the product slurry?

- (a) Diaphragm > Membrane > Mercury
 (b) Diaphragm cell < Membrane cell < Mercury cell
 (c) Membrane cell < Diaphragm cell < Mercury cell
 (d) Mercury cell < Membrane cell < Diaphragm cell

Answers :

1. (b) 2. (b) 3. (d) 4. (d)
 5. (c) 6. (a) 7. (a) 8. (a)
 9. (a) 10. (c) 11. (a, b) 12. (d)
 13. (a) 14. (a) 15. (a) 16. (c)
 17. (a, b, c) 18. (b,c) 19. (a) 20. (c)
 21. (b) 22. (a, b, c, d) 23. (a) 24. (a, b)
 25. (c) 26. (b) 27. (c) 28. (c)
 29. (a, b, c) 30. (a) 31. (d) 32. (b)
 33. (b) 34. (c) 35. (a) 36. (a, c, d)
 37. (b) 38. (a) 39. (b) 40. (c)
 41. (c) 42. (c) 43. (b) 44. (b)
 45. (a)

